



**WACKER
NEUSON**
all it takes!

DW30

Wheel dumper

Compact, safe and a very versatile machine

The all-wheel drive system and the constant tractive force combined with the articulated pendulum joint and the gradeability of up to 50% make the DW30 a real off and on-road pro. At the same time, the low service and maintenance costs associated with it are impressive. An engine with higher performance that gives the DW30 additional power is also available as an option. The optional cab is a benefit when working in the rain, cold or heat. The intuitive operating concept with joystick controls and clearly arranged instrument panel allows the operator to concentrate fully on the task. The high swivel tip skip with tilt sensor fulfills the requirements for all applications. Long maintenance intervals reduce required maintenance to a minimum, saving money and time.

Highlights

- Extended maintenance intervals
- Tilt sensor for the high swivel tip skip
- Automatic brake lights with the hydrostatic braking function
- Auto-stop function
- Sturdy skip guard

Technical Data

Hydraulic

Operating pressure	200.0 bar
hydraulikpump	ZRP
Flow rate	33.0 l/min

Mechanical - Output Details

Gradeability	60.0 %
Travel speed	20.0 km/h
Travel speed (Option)	25.0 km/h

Mechanical Details

Length	3,904.0 - 4,045.0 mm
Width	1,730.0 mm
Height	2,969.0 mm
Weight	1,987.00 kg
Payload	3,000.0 kg
Skip capacity levelled	1,420.0 l
Skip capacity heaped	1,800.0 l
Skip capacity waterlevel	1,110.0 l
Pendulum angle	15.0 °
Operating weight (min.-max.)	2,048.0 - 2,506.0 kg

Engine

Cooling	Water-cooling
Engine type	Diesel engine
Cylinder	3.0
Cylinder capacity	1,116.0 cm ³
Effective power	18.9 KW
Nominal Engine speed	3,000.0 1/min
Exhaust-gas limit	EU Stage V
Manufacturer	Yanmar
Engine designation	3TNV76-UDWN

Environment Data

Sound power LWA, guaranteed	101.0 dB(A)
-----------------------------	-------------

Chassis

Turning radius	3,900.0 mm
Articulation angle	36.0 °
drive unit	Swash plate motor
hydraulikpump	Axialpistonpump
Operating pressure	445.0 bar
Flow rate	66.0 l/min

The illustrations, equipment and data shown may deviate from the current delivery program of your country. Optional equipment subject to additional charge may be shown. Subject to changes.

tires

10.0/75-15.3 10PR

■ **Shipping and Storage**

Shipping weight

1,937.0 kg

Dimensions

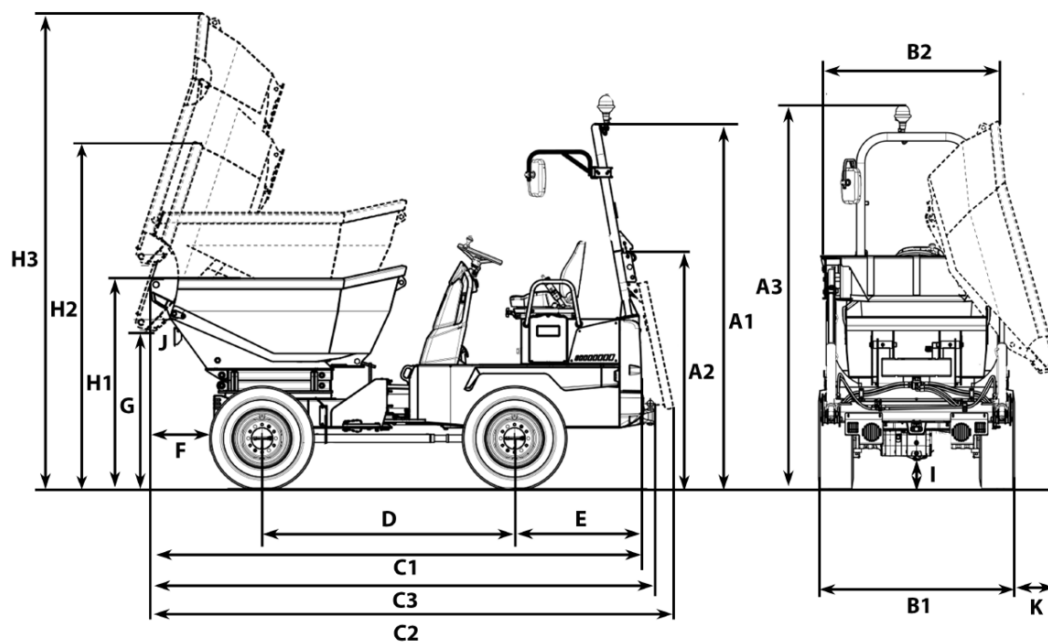

A1	Height ROPS	2,799 mm
	Height with cab	2,689 mm
A2	Height of ROPS tilted	1,913 mm
B1	Width of vehicle	1,730 mm
B2	Width of skip	1,730 mm
C1	Total length ROPS	3,710 mm
	Total length of cab	4,139 mm
C2	Total length ROPS tilted	3,984 mm
C3	Total length with towing device	3,786 mm
D	Wheel base	1,945 mm
E	Rear overhang	963 mm
F	Dumping width	543 mm
G	Dumping height max.	233 mm
H1	Skip height	1,473 mm
H2	Skip height tilted	2,074 mm
I	Ground clearance	257 mm
J	Dumping angle	48 °