



DV60

Dual View Dumper

Compact, off-road site dumper

With the Dual View Dumper concept, safety has been redefined. The rotatable operator's seat is easy and efficient to use. With the 180° rotation, the operator maintains an excellent view of the skip with its content as well as the work area. Visibility is unmatched with the 360° view. In the main direction of travel, the operator has a perfect field of vision, similar to a truck, and with the hydrostatic drive system with automatic ECO mode, valuable time and money are saved on the construction site. As a result, the machines are comfortable to operate. Comfort features in the control stand/operator area as well as outside of the machine were included in the development. Comfortable step heights when entering and exiting, extensive storage options and comfort round off the overall package.

Highlights

- Rotating seat
- Hydrostatic 4-wheel drive with automatic ECO mode
- Field of vision - Better than the standards
- Cab
- Sturdy skip guard

Technical Data

Hydraulic

Operating pressure	235.0 bar
hydraulikpump	ZRP
Flow rate	70.0 l/min
Tank capacity	60.0 l

Mechanical - Output Details

Gradeability	55.0 %
Travel speed	25.0 km/h
Travel speed (Option)	30.0 km/h

Mechanical Details

Length	4,575.0 mm
Width	2,250.0 mm
Height	3,110.0 mm
Weight	4,483.00 kg
Weight cabin	4,683.0 kg
Weight ROPS	4,483.0 kg
Payload	6,000.0 kg
skip	Front tip skip
Skip capacity levelled	2,650.0 l

Skip capacity heaped	3,500.0 l
Skip capacity waterlevel	1,900.0 l
Pendulum angle	11.0 °
Operating weight (min.-max.)	4,148.0 - 4,733.0 kg

Engine

Cooling	Water-cooling
Engine type	Turbodieselengine
Cylinder	4.0
Cylinder capacity	3,400.0 cm3
Tank capacity	83.0 l
Effective power	55.0 KW
Nominal Engine speed	2,200.0 1/min
Standard (Effective power)	ISO 3046
Exhaust-gas limit	IIIB/Tier IV Final
Manufacturer	Perkins
Engine designation	854F

Environment Data

Sound power LWA, guaranteed	101.0 dB(A)
-----------------------------	-------------

■ Chassis

Turning radius	6,100.0 mm
Articulation angle	29.0 °
drive unit	4WD hydrostatic
hydraulikpump	Axialpistonpump

Operating pressure	450.0 bar
Flow rate	123.0 l/min
tires	405/70-20

■ Shipping and Storage

Shipping weight	4,002.0 kg
-----------------	------------

Dimensions

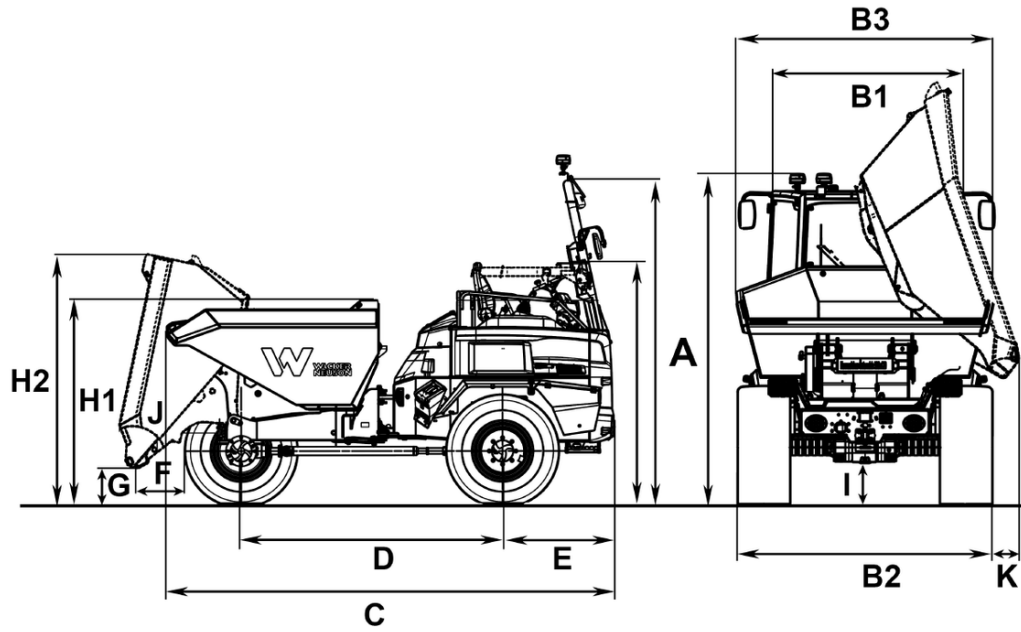

A	Height ROPS	3,377 mm
	Height with cab	2,940 mm
	Height of canopy	2,940 mm
	Height of ROPS tilted	2,400 mm
	Height of cab with rotating beacon	3,078 mm
	Height ROPS with rotating beacon	3,617 mm
B1	Width of cab	1,563 mm
B2	Width of vehicle	2,230 mm
B3	Width of skip	2,328 mm
C	Total length ROPS	4,448 mm
	Total length of cab	4,448 mm
D	Wheel base	2,485 mm
E	Rear overhang	1,157 mm
F	Dumping width	565 mm
G	Dumping height max.	385 mm
H1	Skip height	2,028 mm
H2	Skip height tilted	2,463 mm
I	Ground clearance	370 mm
J	Dumping angle	50 °