



DT10

Track dumper

The professional machine

The hydrostatic drive system allows for quick and convenient operation and the single-piece engine hood, as well as the optimal arrangement of the service points, make daily maintenance much easier. The rubber tracks and the excellent weight distribution reduce the ground pressure, ensuring more extensive application uses. The variety of skip versions make it a very versatile machine.

Highlights

- Hydrostatic drive
- Small dimensions
- Hanging suspension-mounted rollers

Technical Data

Hydraulic

hydraulikpump	Variable displacement and gear pump
Flow rate max.	66.0 l/min

Mechanical - Output Details

Gradeability	36.0 %
Travel speed	4.0 km/h

Mechanical Details

Length	2,670.0 mm
Width	830.0 mm
Height	1,280.0 mm
Weight	680.00 kg

Payload max.	1,000.0 kg
Skip capacity heaped	427.0 l
Operating weight (min.-max.)	665.0 - 915.0 kg

Engine

Engine type	Diesel engine
Effective power	9.6 KW
Nominal Engine speed	3,600.0 1/min

Environment Data

Sound power LWA, guaranteed	101.0 dB(A)
-----------------------------	-------------

Shipping and Storage

Shipping weight	590.0 kg
-----------------	----------

Dimensions

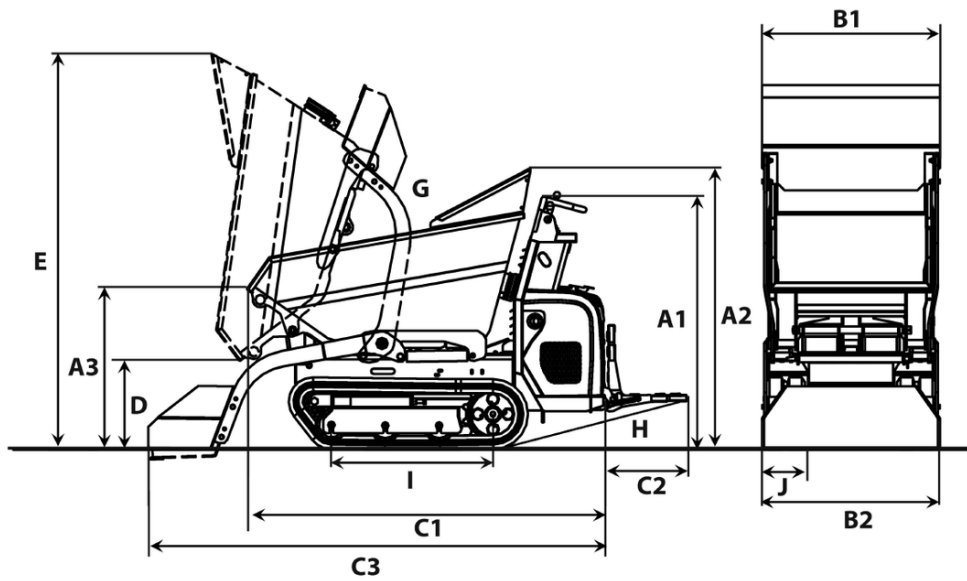

A1	Height above operator's stand	1,280 mm
A2	Height over skip hand guard	1,365 mm
A3	Height front edge of skip	812 mm
B1	Width of skip	790 mm
B2	Width of undercarriage	790 mm
B7	Width with self-loading equipment	830 mm
C1	Total length without footboard	1,800 mm
C2	Length footboard	393 mm
C3	Length with self-loading equipment, without footboard	2,267 mm
D	Dumping height max.	474 mm
E	Skip height tilted	1,905 mm
G	Dumping angle	70 °
H	Rollback angle footboard	14 °
I	Length chain stand	875 mm
J	Track width	180 mm